



hidrive
MAKE CERTAIN

SERVICE BODY ACCESSORIES

Accessories to fit out your service body to get the job done right.

MADE
HERE, FOR
CERTAIN

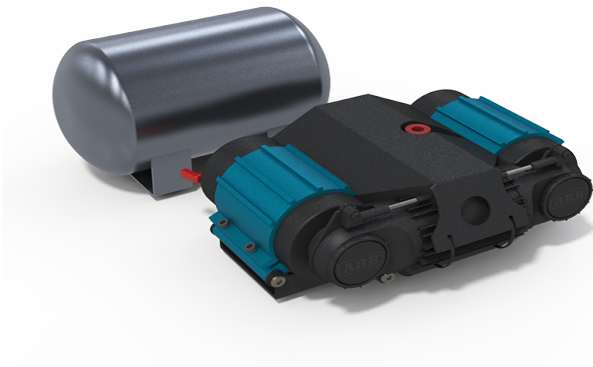

DC TWIN AIR COMPRESSOR WITH AIR TANK

Providing optimum power, the ARB twin motor design delivers smooth air flow for fast inflation of tyres. Constructed of lightweight, high-strength engineering grade materials, it incorporates quality components for quiet operation and long life. Comes complete with a full wiring harness, Carling style switch, inbuilt relay and pressure switch.

Includes installation, plumbing, electrical cabling, switching and circuit protection.

Options:

- 12V with 18LTR tank
- 24V with 18LTR tank

Features & Benefits:

- Low voltage electric air compressors with twin motors that incorporate internal thermal protection against extreme temperature damage
- Ideal for mechanics and other trades needing ability to pump up tyres fast
- Durable 18 litre pressure vessel included
- High quality materials
- Plumbed to compressor

Details:

- | | |
|-----------------|---------------------------------|
| ☑ Compatibility | Ute, Trailer, Truck |
| ☑ Warranty | 12 Month manufacturers warranty |

[VIEW ONLINE](#)

**DC TWIN AIR COMPRESSOR WITH AIR
TANK 12V with 18LTR tank**

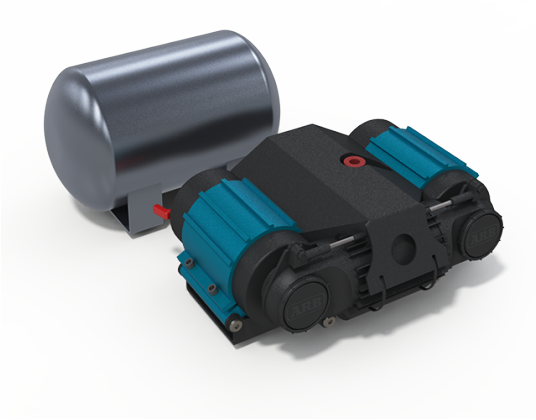

**DC TWIN AIR COMPRESSOR WITH AIR
TANK 24V with 18LTR tank**

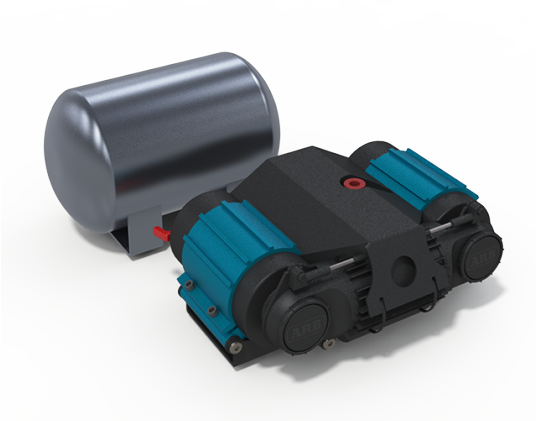



Chat with one of our helpful Mobile Workspace Specialists.

→ 1300 350 625

→ team.aus@hidrive.com.au

→ hidrive.com.au

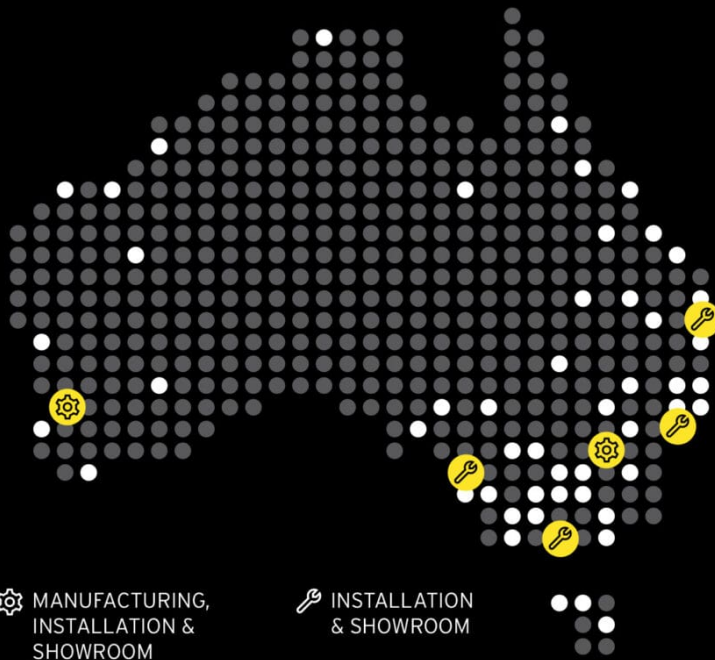

MANUFACTURING, INSTALLATION & SHOWROOM

INSTALLATION & SHOWROOM

Hidrive is the only manufacturer of service bodies for utes, trailers and trucks with a company-owned national installation network.



Eastern Manufacturing, Installation & Showroom
17 O'Sullivan Pl, Goulburn NSW 2580



Brisbane Showroom & Installation
146 Crockford St, Northgate QLD 4013



Melbourne Showroom & Installation
57 Hunter Rd, Derrimut VIC 3026



Western Manufacturing, Installation & Showroom
18 Catalano Rd, Canning Vale WA 6155



Sydney Showroom & Installation
10 Garner Pl, Ingleburn NSW 2565



Adelaide Showroom & Installation
6 Worriga St, Regency Park SA 5010