

Revision	Date	Description of changes	Notes
0	July 2024	Product launch	

This manual is the property of Hidrive. It is not to be copied without prior written consent.

REAR STEP, UNIVERSAL, SUITS HIDRIVE TOWBAR

OPERATOR MANUAL

HD-OM-3

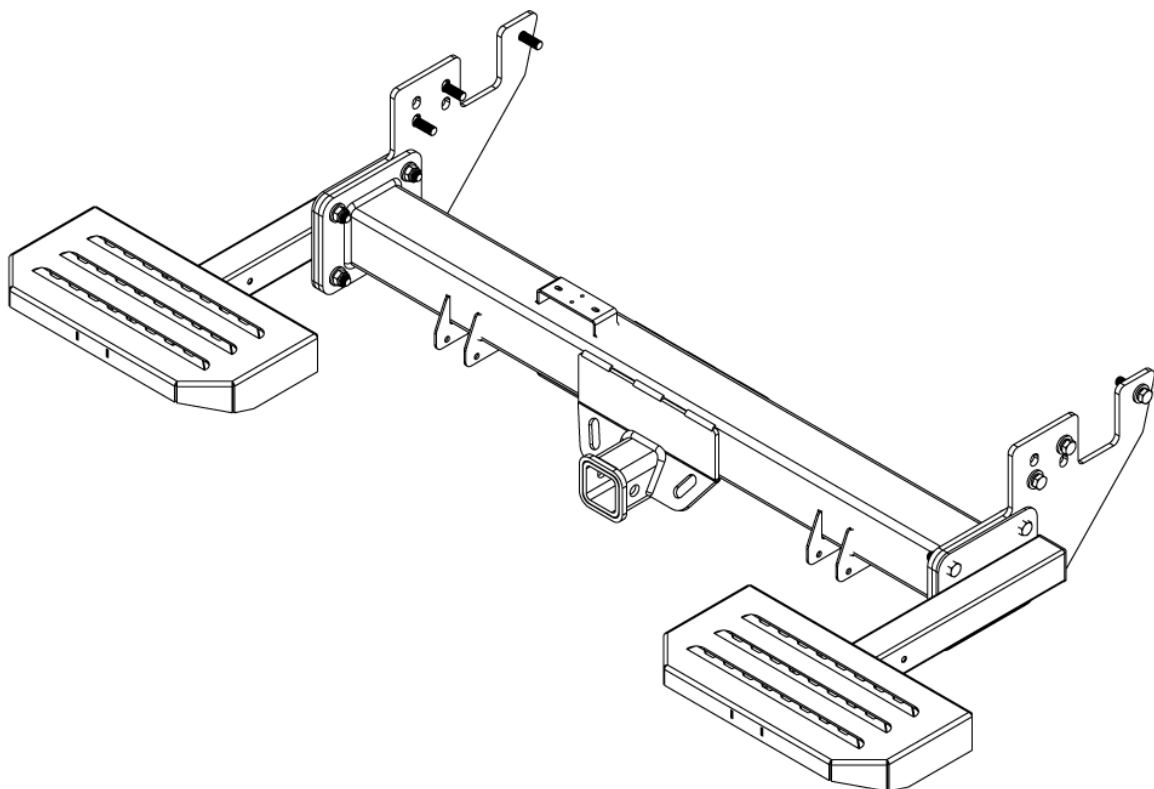

SAFETY WARNINGS

- a) Read, understand and retain these instructions for future reference.
- b) **MAXIMUM LOAD RATING 150KG.**
- c) Incorrect use and failure to observe safety warnings may result in serious injury or death.
- d) The vehicle **MUST** be stationary before use of this product.
- e) Not to be used as a vehicle recovery point



These warnings must be read and understood in conjunction with any warnings from the vehicle manufacturer.

Modifications to this product that are not approved by Hidrive Engineering may affect the safety and integrity of the product and void warranty.

CUSTOMER SERVICE

For all your service and parts needs please contact Hidrive Customer Care:

Call **1300 325 845**

Email customercare@hidrive.com.au

Our Customer Care team is here to support you to keep your fleet on the road with minimal downtime for years to come.

INSTALLATION

Fitment Time: 15mins

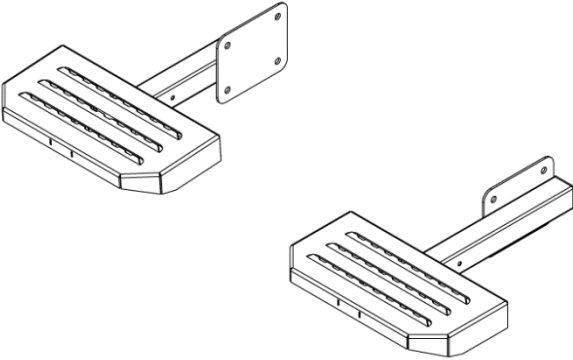
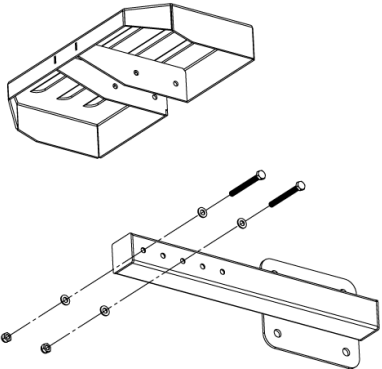
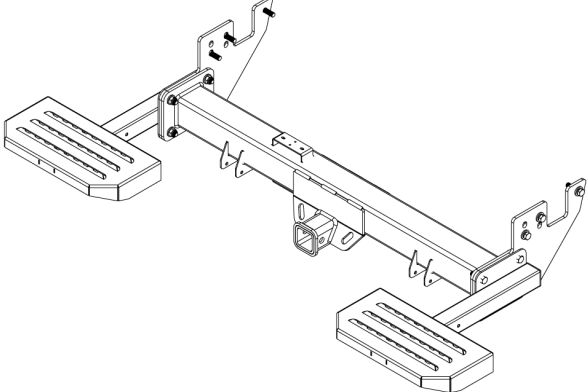
<p>STEP 1 Unwrap all components and layout on a protective surface so as not to scratch powder coat before installation.</p> <p>Determine which side of the vehicle the step is to be installed.</p> <p>NOTE: Base flange mounts directly onto the outside of a Hidrive Towbar.</p>	
<p>STEP 2 Determine the distance from the vehicle the tread should be mounted.</p> <p>Install Tread to Base using the supplied two M8 x 75mm hex head bolts, four M8 flat washers and two M8 Nyloc nuts.</p> <p>Tools:</p> <ul style="list-style-type: none">• 13mm socket or spanner for the M8 bolts and Nyloc nuts. <p>Ensure all M8 hardware is tightened to 25 Nm.</p>	
<p>STEP 3 Install the Rear Step Assembly to the outside flanges of a Hidrive Towbar utilising the M12 towbar hardware.</p> <p>Tools:</p> <ul style="list-style-type: none">• 18mm and 19mm socket or spanners for the M12 bolts and Nyloc nuts <p>Ensure all M12 hardware is tightened to 90 Nm.</p> <p>Mark heads of bolts to show that they have been torqued to correct specification.</p>	

MAINTENANCE CHECKS

Check all mounting/fixing and connecting points for security/fatigue or tamper.

IMPORTANT: Immediately stop using the rear step if there is damage that affects function or safety.

CLEANING

Washing procedure is the same as for your vehicle paintwork. Refer to your vehicle manufacturer's cleaning instructions.