



4T RATED RECOVERY POINT

OVERVIEW

Designed, tested, and made in Australia. The Hidrive 4T Rated Recovery Point has been engineered to safely and reliably assist with vehicle recovery.

The Hidrive recovery point fits on the ends of any Hidrive ute towbar. The kit comes as a pair as standard to give more flexibility when planning your recovery.

Please follow the operator's manual instructions when using the recovery point. To only be used with 4.75T rated bow shackles.



TECHNICAL SPECIFICATIONS

Material:	12mm Bisalloy 100 structural steel
Dimensions:	260mm L x 170mm H x 12mm W
Weight:	3.4kg per recovery point
Load Rating:	4000kg per recovery point
Maximum Recovery Angle:	30 degrees
Recommended Lug:	4.75T rated bow shackle only
Finish:	Gloss red powdercoat
Vehicle Fitment:	Compatible with any Hidrive ute towbar

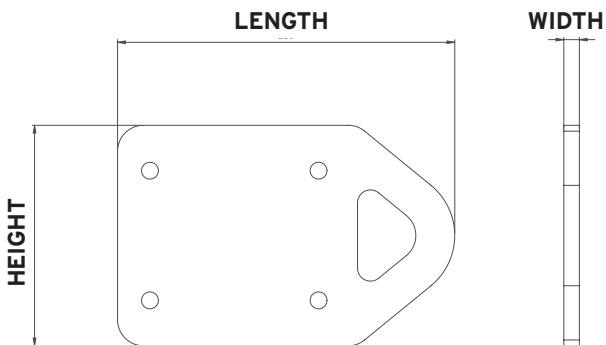

FEATURES & BENEFITS

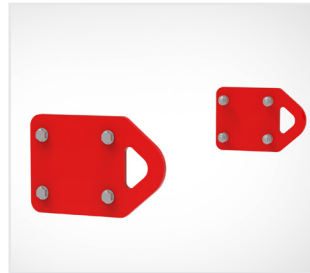

Complete Kit, Pair = 2 Recovery Points + Hardware

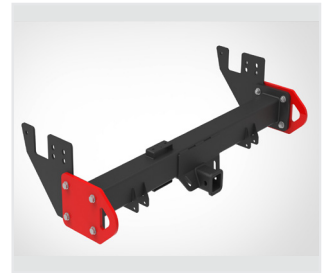

Easy Fitment



Durable Gloss Red Powdercoat Finish

CONTACT US

To find out more please contact your Hidrive Mobile Workspace Specialist to discuss your needs.

www.hidrive.com.au 1300 325 845

